

CUSTOMER: P/N: 31290B REV. . APPROVED BY:

REVISIONS		
REV.	DESCRIPTION	DATE
△		
△		

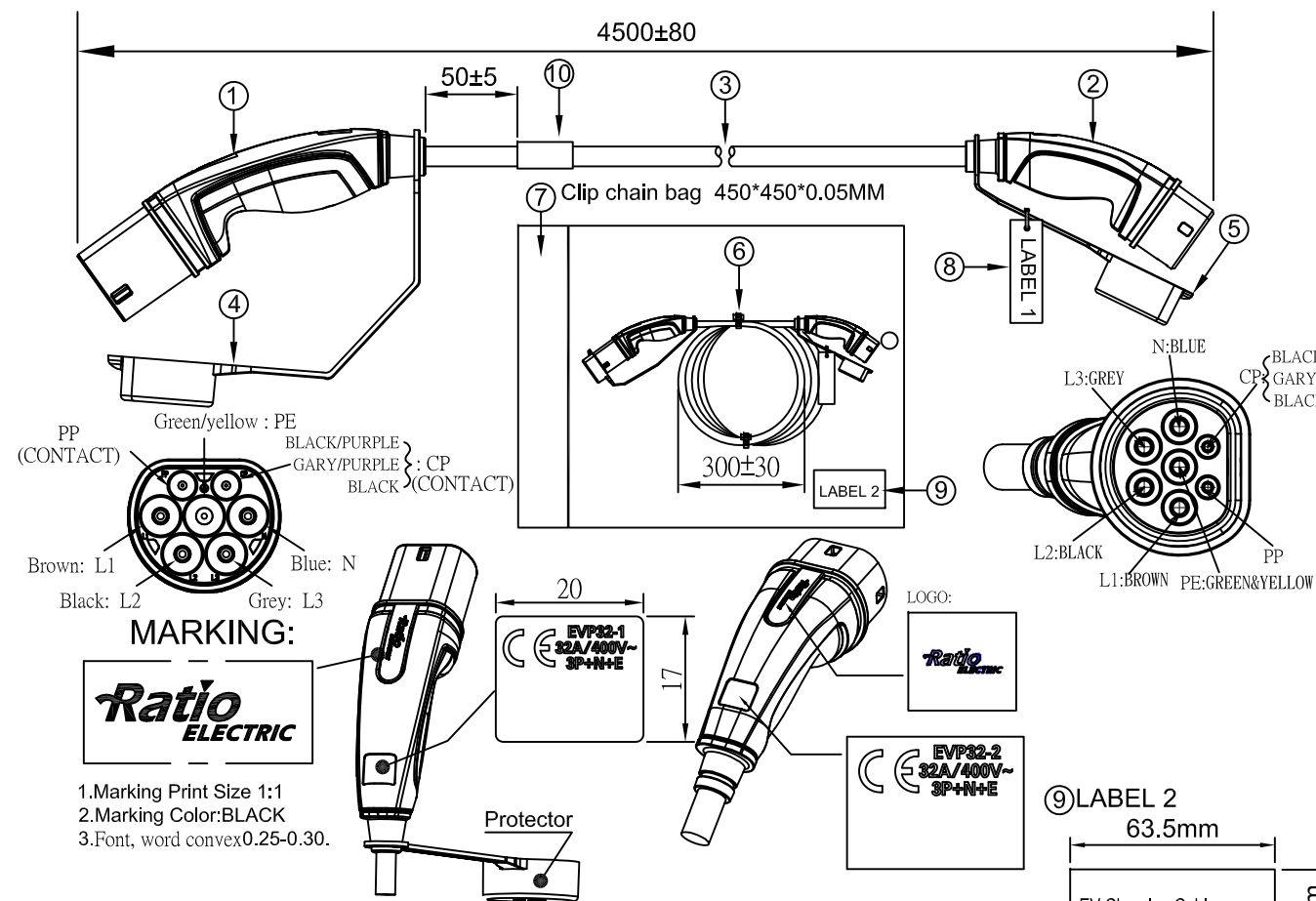

NOTES:

- The outer box label needs to be labeled with the serial number of the serial number.
For example, the content of the 50PCS tag serial number is "WS-000001~WS-000050" (*Contents are based on customer)
The outer box label needs to be added:
"Serial No.:WS-000001~WS-000050"

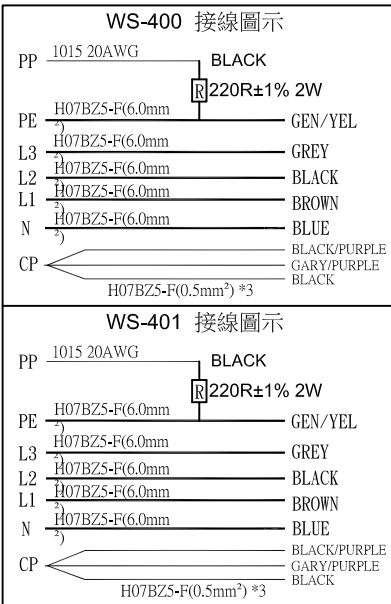

MARKING:
Ratio ELECTRIC
 1. Marking Print Size 1:1
 2. Marking Color: BLACK
 3. Font, word convex 0.25-0.30.

ITEM	DESCRIPTION	COLOR	QTY
⑩	LABEL3	---	1
⑨	LABEL 2	---	1
⑧	LABEL 1+ Cable ties BLACK	---	1
⑦	Clip chain bag 450*450*0.05MM	---	1
⑥	Cable ties	BLACK	2
⑤	WS-401 Waterproof cover	BLACK	1
④	WS-400 Waterproof cover	BLACK	1
③	H07BZ5-F 5G 6.0mm ² +3x0.5mm ²	BLACK	1
②	WS-401 32 (A) 400 (V)+ Resistance 220R ±1% 2W	GREY	1
①	WS-400 32 (A) 400 (V)+ Resistance 220R ±1% 2W	RAL 7023	1

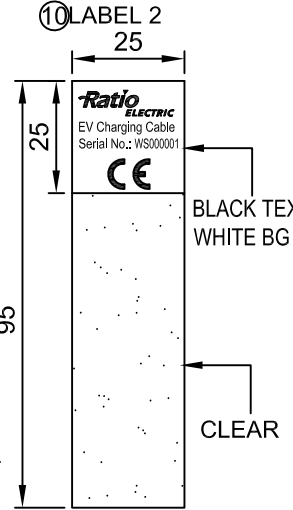
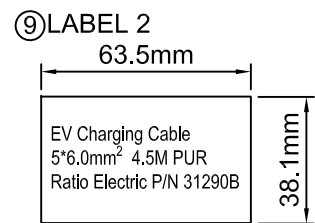

SIGNATURE		Ratio Electric B.V.		
SAFETY ENGINEER:		www.ratio-electric.com		
MANAGER BY:		PRODUCT NO.: 400+401	DATE: 2018/07/30	
CHECKED BY:		UNIT: mm	SHEET: 1 OF 1	REV.
DRAWN BY:		DWG NO: 0318-0274		
				C